

Automated Discovery for Design and Control of Turbulent Systems (AutoDIDACTS)

Dr. Mukund Vengalattore
Defense Sciences Office
DARPA

Proposer's Day

April 1, 2026



Distribution Statement "A" (Approved for Public Release, Distribution Unlimited).



Agenda



AutoDIDACTS Proposers Day			
April 1, 2026 All Times are Eastern			
9:30 AM	10:00 AM	Log-in, Sound Check, Administrative procedure announcements	
10:00 AM	10:15 AM	Defense Sciences Office (DSO) Overview, Jim Gimlett	
10:15 AM	10:30 AM	Contract Management Office (CMO) Briefing, Thao Phan	
10:30 AM	11:15 AM	AutoDIDACTS Overview, Mukund Vengalattore	
11:15 AM	12:30 PM	Lunch Break (All Questions Submitted by 11:30am)	
12:30 PM	2:15 PM	Lightning Rounds (5 mins ea) ~19 lightning rounds	
2:15 PM	3:00 PM	Q and A	
Sidebar Discussions: 8 mins each + 2 mins for transition to the next breakout room			
3:00 PM	3:10 PM	Participant Sidebar No. 1	Contracts Management Office Sidebar (separate Zoom link)
3:10 PM	3:20 PM	Participant Sidebar No. 2	
3:20 PM	3:30 PM	Participant Sidebar No. 3	
3:30 PM	3:40 PM	Participant Sidebar No. 4	
3:40 PM	3:50 PM	Participant Sidebar No. 5	
3:50 PM	4:00 PM	Participant Sidebar No. 6	
4:00 PM	4:10 PM	Participant Sidebar No. 7	
4:10 PM	4:20 PM	Participant Sidebar No. 8	
4:20 PM	4:30 PM	Participant Sidebar No. 9	
4:30 PM	4:40 PM	Participant Sidebar No. 10	
4:40 PM	4:50 PM	Participant Sidebar No. 11	
4:50 PM	5:00 PM	Participant Sidebar No. 12	



AutoDIDACTS Proposer's Day Goals



- Present AutoDIDACTS to the community
- Convey scientific objectives and expectations of the AutoDIDACTS effort
- Scientific merits of a successful proposal
- Q&A (please send questions to AutoDIDACTS@darpa.mil)
 - Q&As will be published in a FAQ attached to the AutoDIDACTS website
 - www.darpa.mil/work-with-us/opportunities



Problem: Need rapid and efficient exploration, innovation, and optimization in aeronautical design

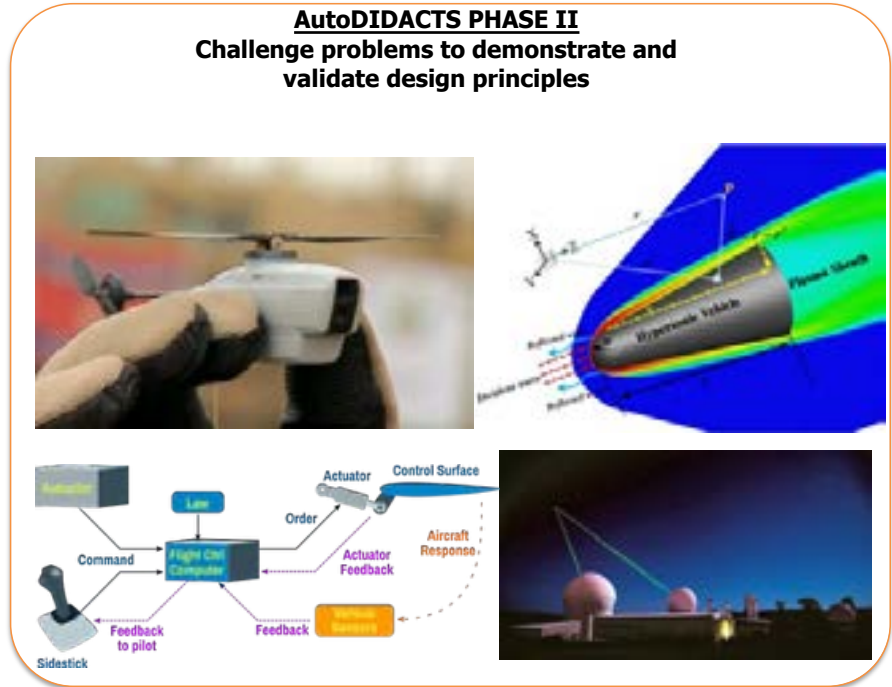
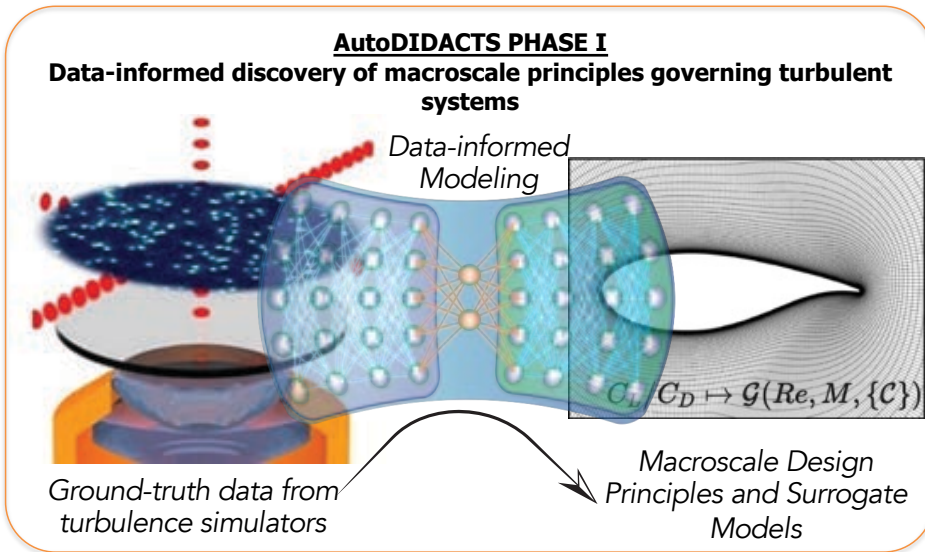

AutoDIDACTS will demonstrate and validate new data-informed paradigms for design exploration and optimization across various regimes of aeronautics and turbulent control problems



Impact of Design on Cost and Developmental Timescales

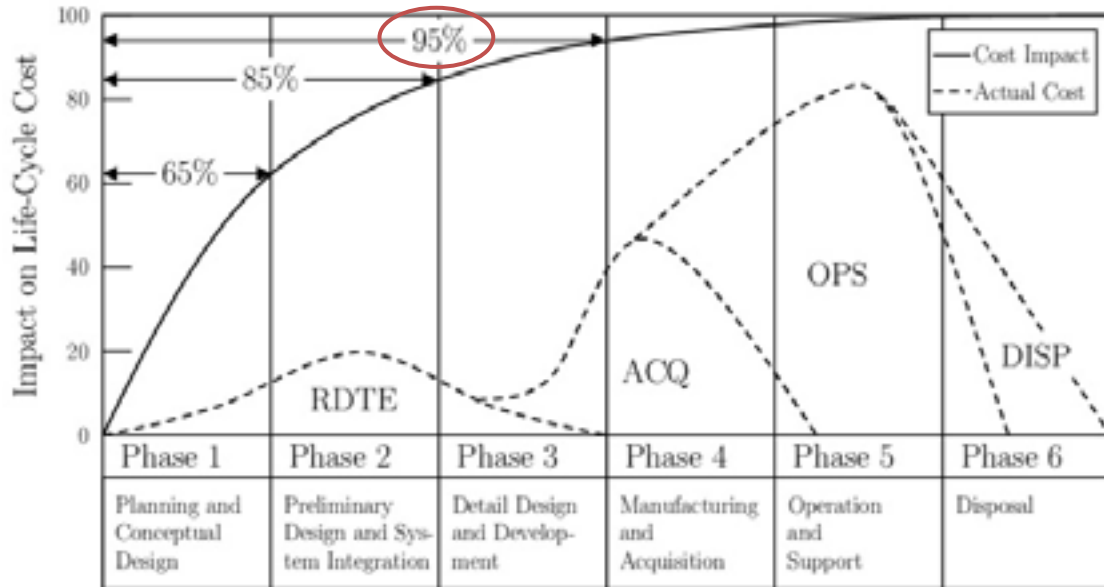

Airplane Cost Estimation, Roskam, RAND (1989)

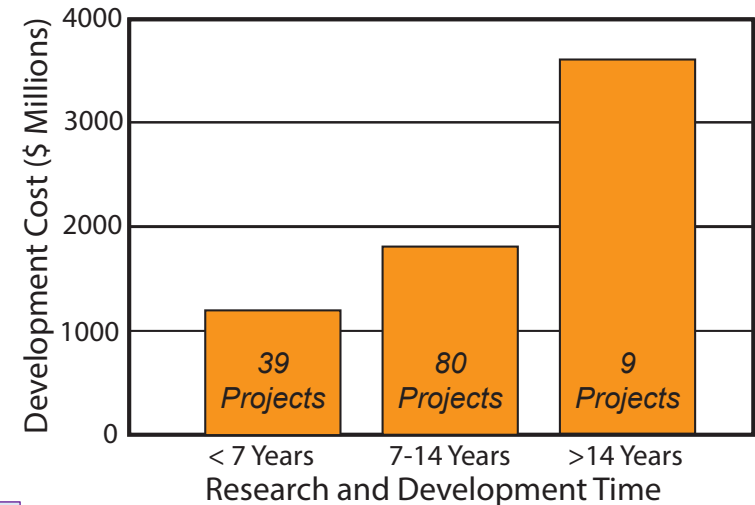

Reducing DoD product development time (MIT)

- The design & development phase determines up to **95%** of the life-cycle cost of an aircraft
- Design iterations and development time have a dramatic impact on cost
- Despite the impact of the design phase on LCC and R&D duration, precise knowledge of aircraft performance is not achieved until full-scale prototype flight testing



Prohibitive Costs and Limitations in Turbulence Modeling



SOA wind-tunnel facilities

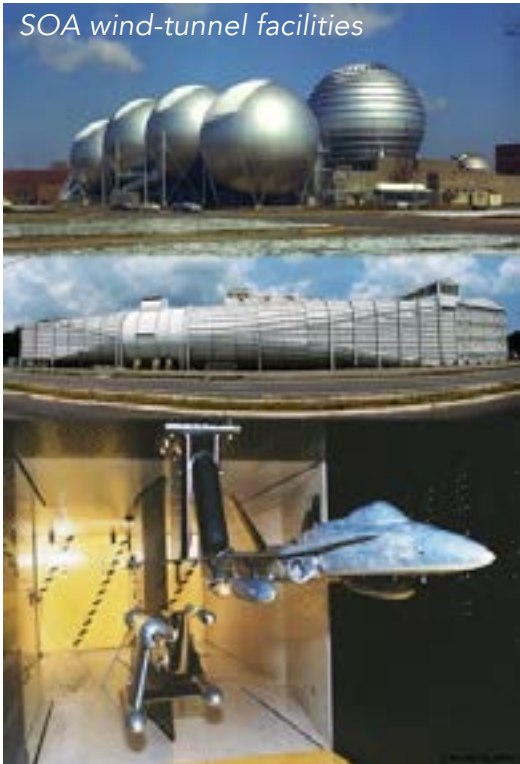

- Wind-tunnels
 - Are extremely expensive to scale up to large parameter ranges
 - Yield minimal data at relevant spatiotemporal scales
- Computational approaches
 - Prohibitively larger resources for increased accuracy
 - Tractable computational models rely extensively on ad hoc heuristics with limited generalizability

Example assessment following the DARPA MAV program:

"The nature of the MAV rotor flow probably violates most, if not all, of the assumptions made in the development of fundamental theories of rotor analyses. What we lack are methods that allow for small-scale rotor design, and until such methods become established, MAVs will continue to demonstrate much lower levels of performance capability than is desired"

- Towards understanding the Aerodynamic Efficiency of a Hovering Micro-Rotor
J. Am. Heli. Soc. (2008)



SOA computing clusters for CFD



CFD: computational fluid dynamics
MAV: Micro Air Vehicles

Distribution Statement "A" (Approved for Public Release, Distribution Unlimited).



Computational aerodynamics

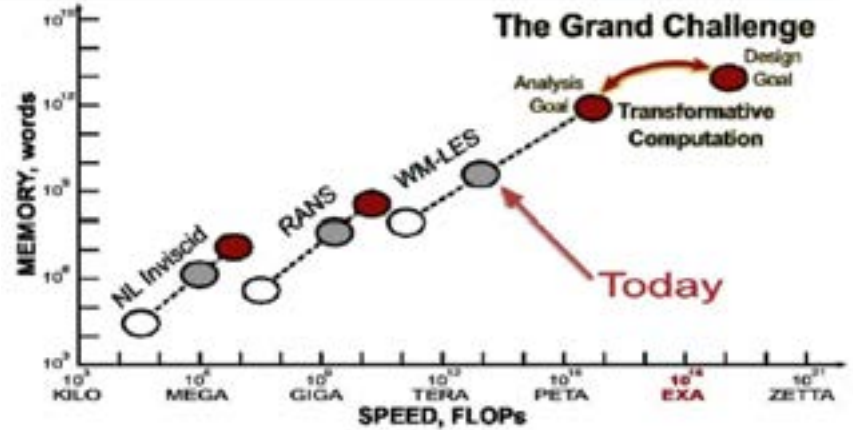
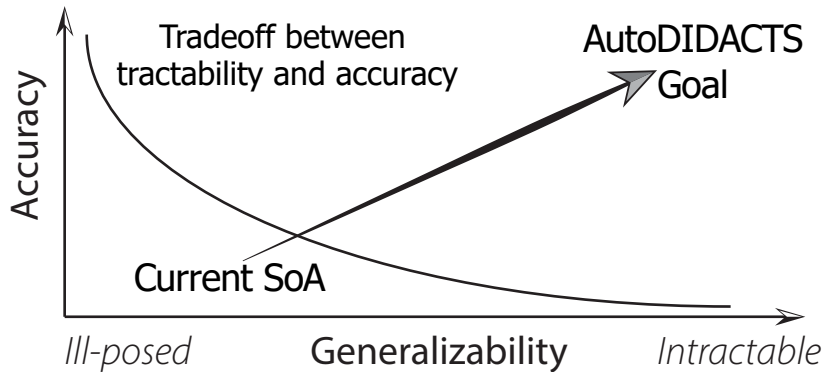
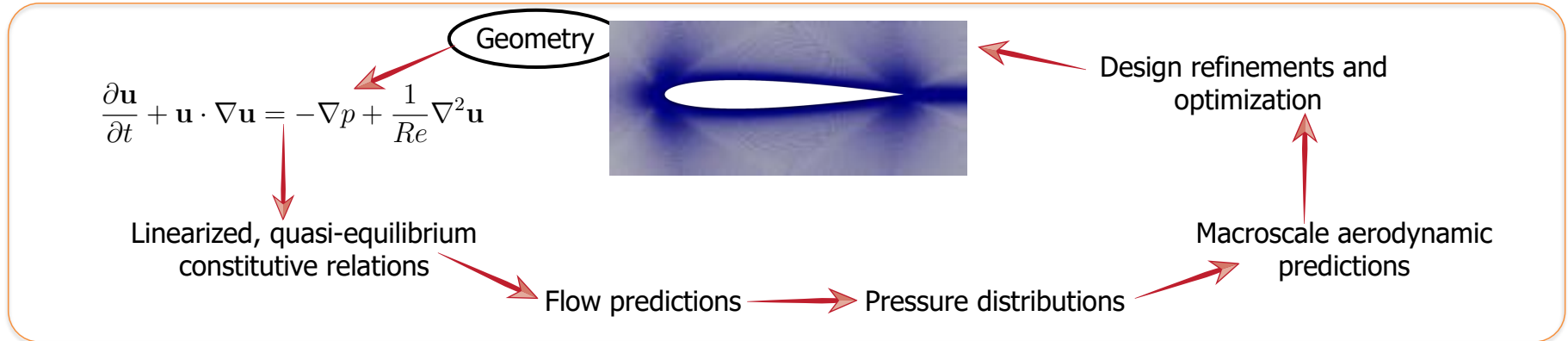

If 'computer aerodynamics' is to realize its full potential, then more attention must be devoted to underlying principles.



Turbulence modeling, design & control: challenges

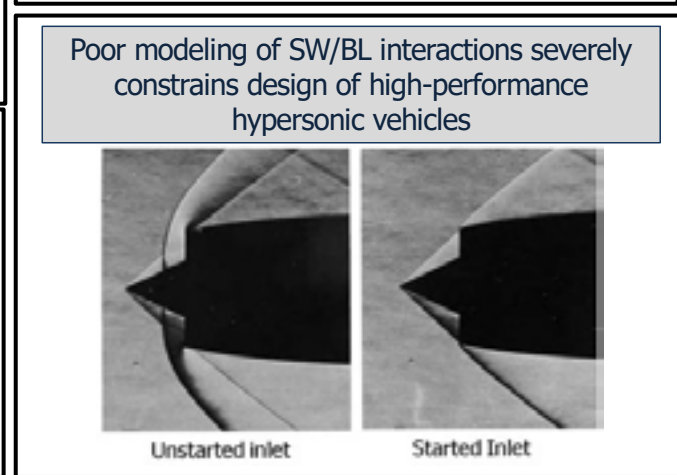
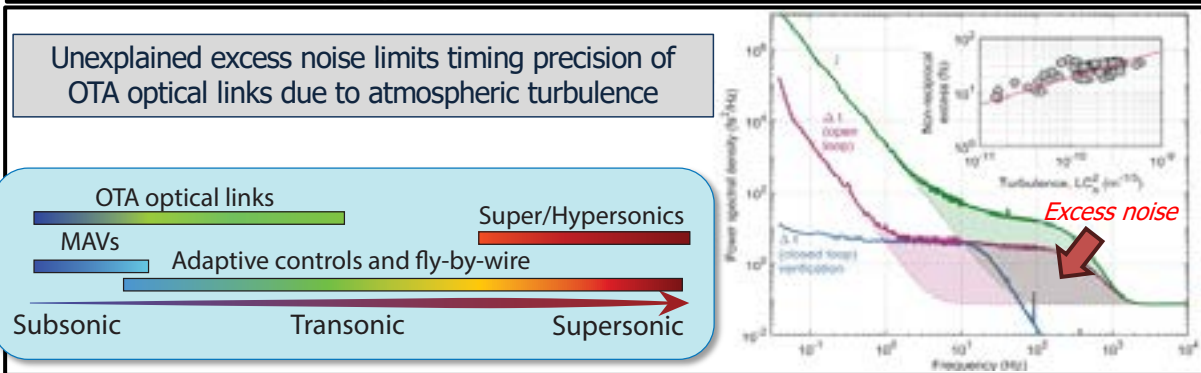
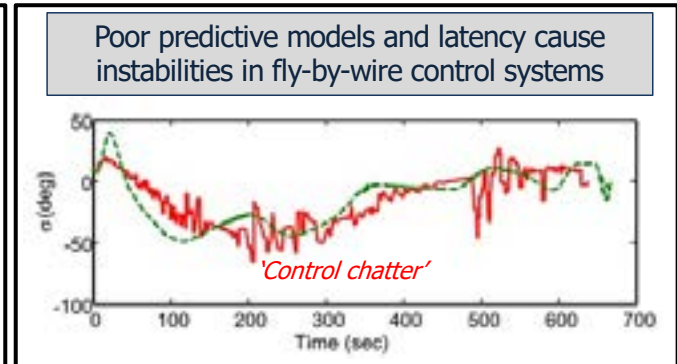
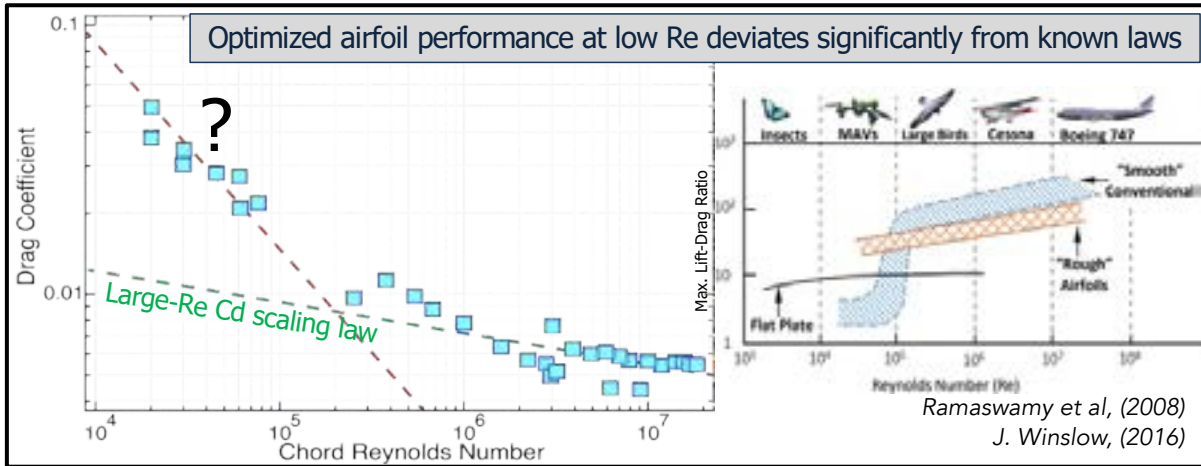

Across regimes, innovation is stymied by absence of rigorous principles and models that govern turbulent flows

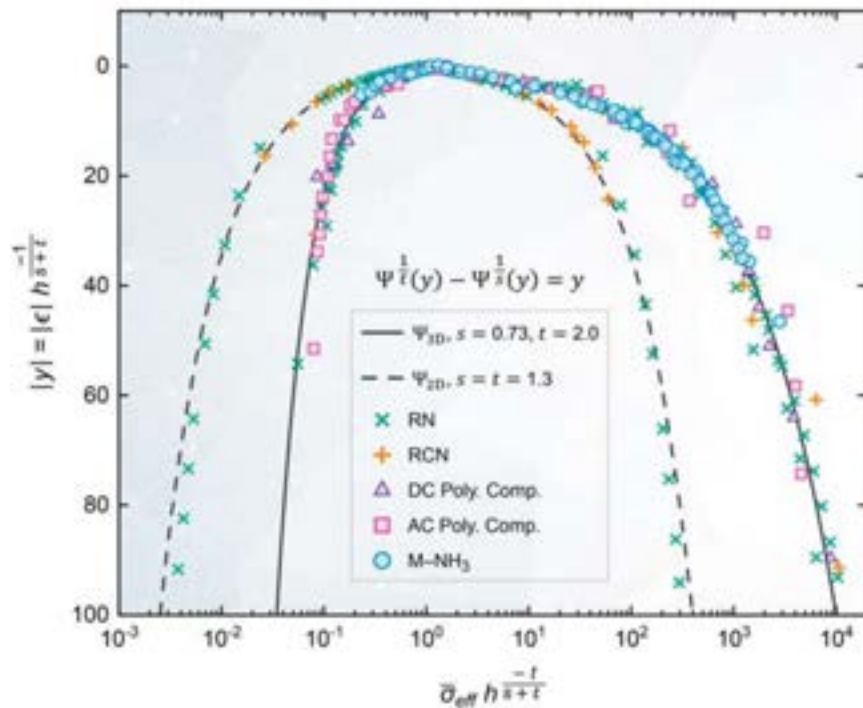

Electrical and thermal percolation in polymer composites
Sarikhani et al, (2022)

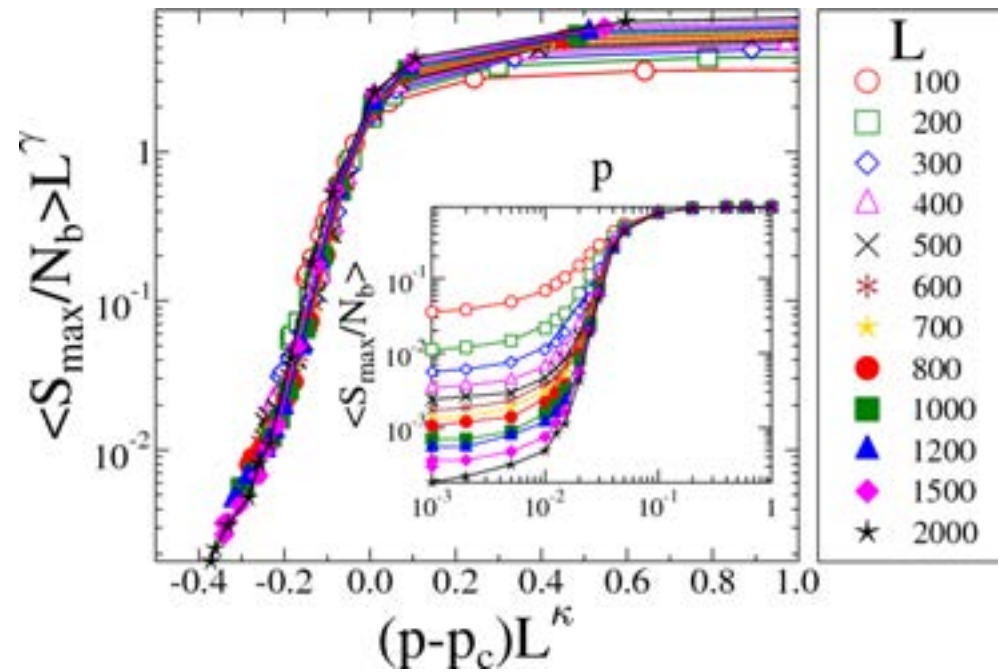

Scaling laws of failure dynamics in complex networks,
Pal et al, (2023)

Complex multiscale systems can exhibit universal macroscale and emergent behavior that is relatively insensitive to microscopic details



Insight: signatures of Universality across flow regimes

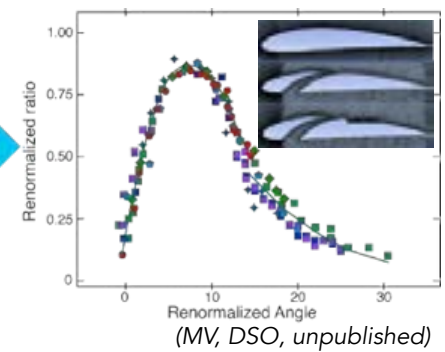
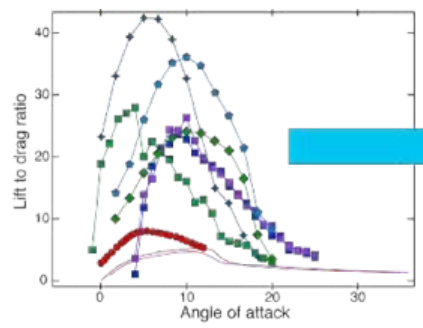
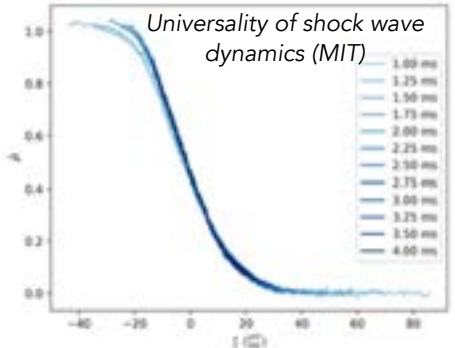
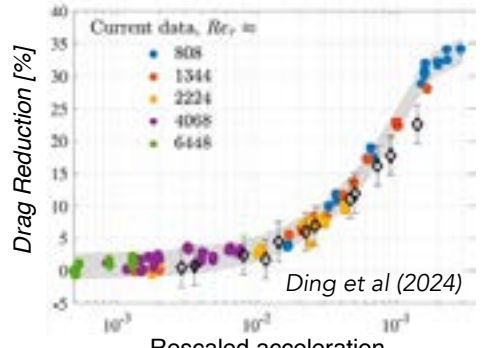
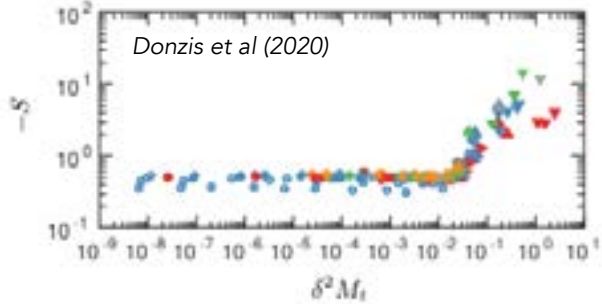
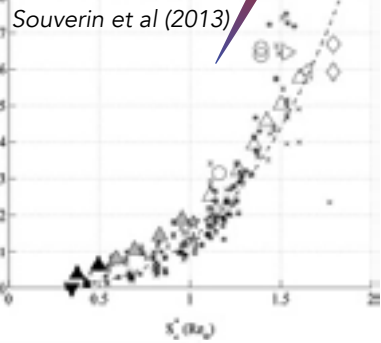
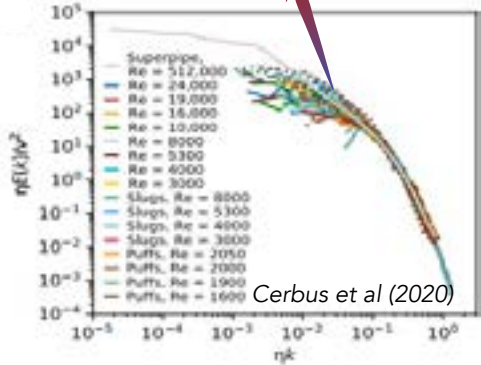
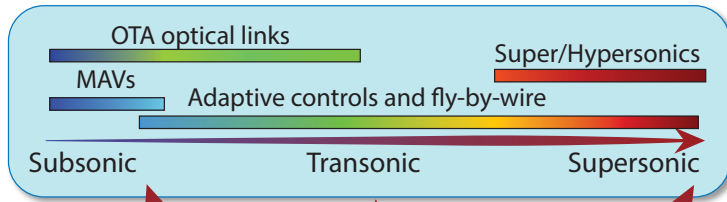

Insight: Strong empirical signatures of universal macroscale behavior across orders of magnitude in flow regimes.
Questions: What are the governing functions? How do we uncover the underlying macroscale design principles?



Data-informed discovery of macroscale principles governing turbulent systems

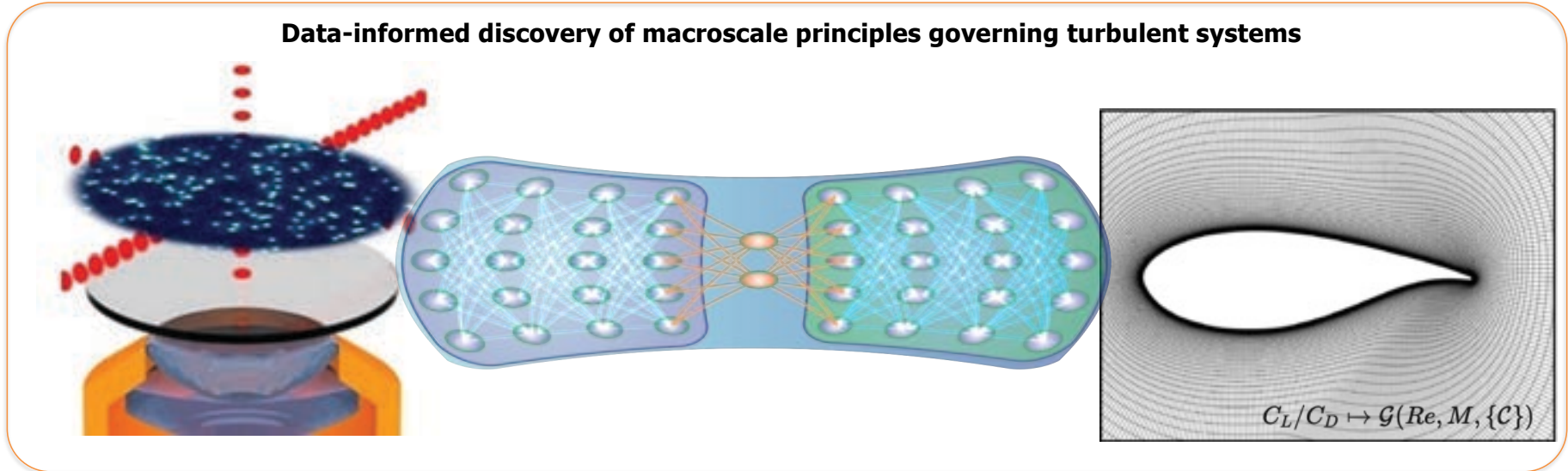

1. Ground-truth data from compact turbulence simulators:

- Wide tunability and control
- High throughput data acquisition
- Precision measurement capabilities

2. Data-informed Modeling:

- Use of simulator data to extract macroscale principles
- Uncertainty and robustness quantification
- Generalizability across wide parameter ranges

3. Macroscale Design Principles and Surrogate Models

- Validation of design principles
- Interpretability and traceability to established design principles



1. Tabletop Simulators of Turbulent Phenomenology



- Compact experimental systems capable of accessing the **relevant turbulence regimes**.
- **Tunability** across parameter space: Reynolds number, geometry, dimensionality
- The '**measurement problem**': Can we go beyond current bottlenecks in high Reynolds number, high Mach number measurement capabilities?
- **High resolution time-series measurements** of density, velocity profiles, enthalpy etc.
- From single-point measurements to **multi-point correlations**

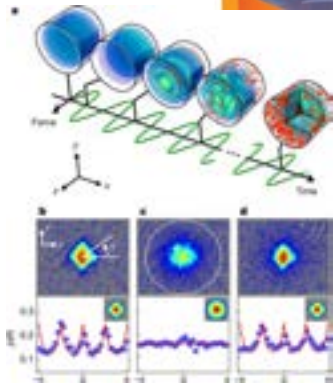
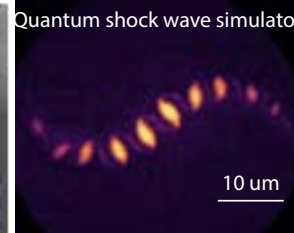
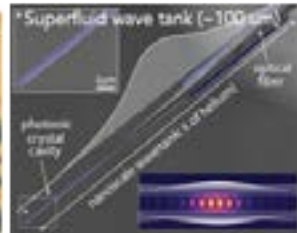
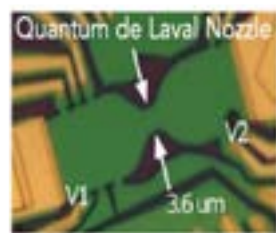
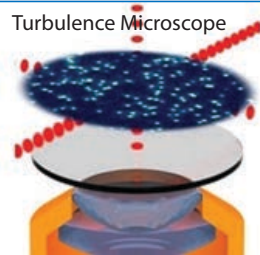

Ultracold atomic gases

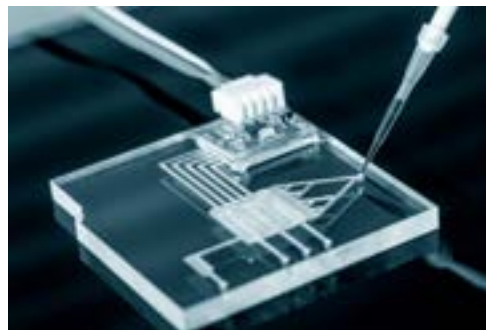

Microfluidics

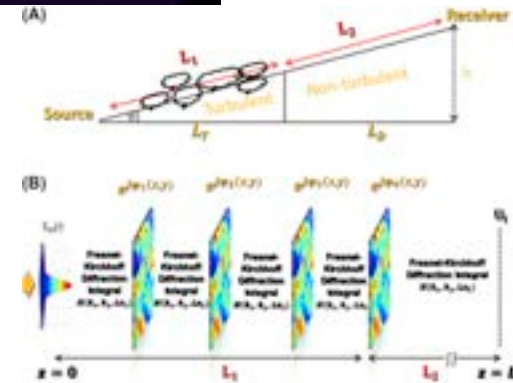

Optical simulators

Distribution Statement "A" (Approved for Public Release, Distribution Unlimited).



2. Data-informed automated discovery of governing laws

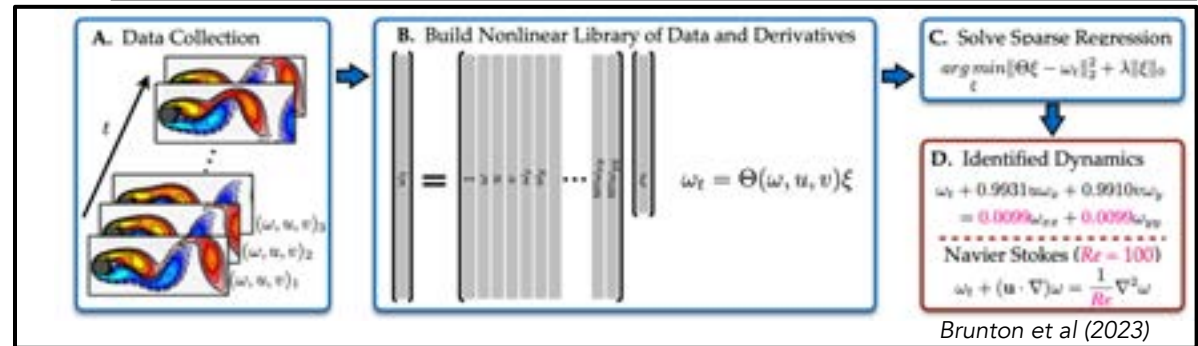
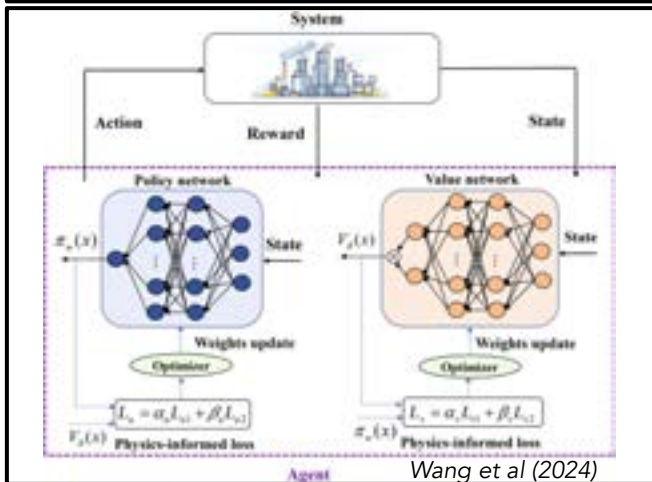
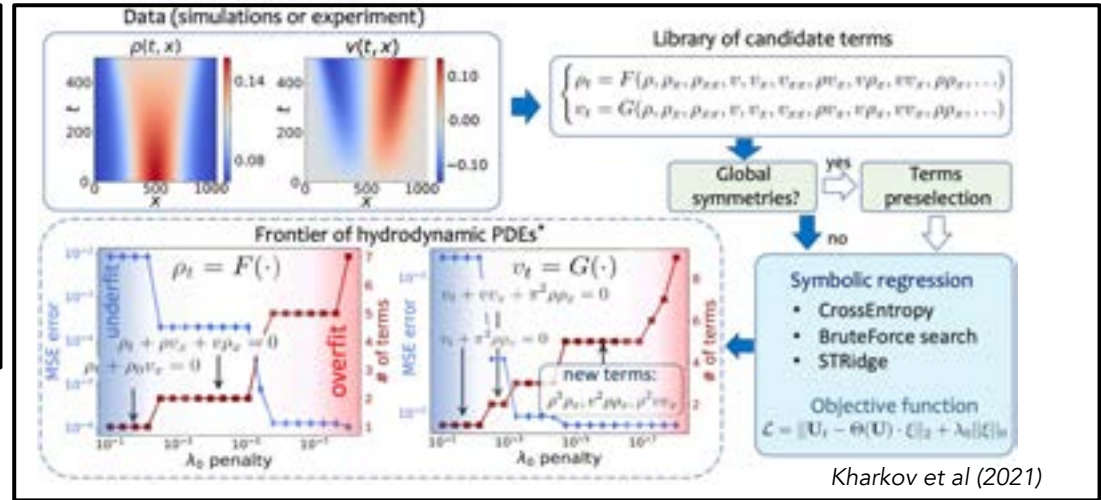
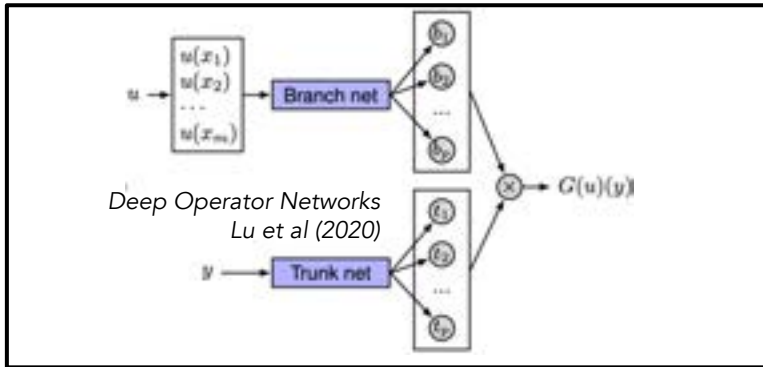

A diverse range of data-informed AI/ML techniques for the automated discovery of macroscale governing laws



3. Interpretability of design principles and surrogate models

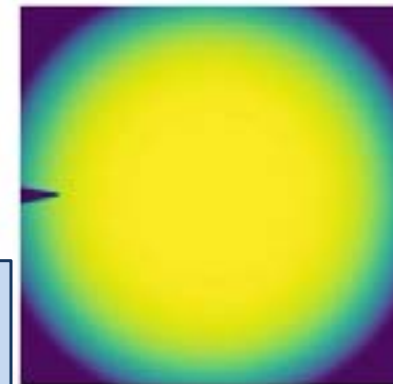
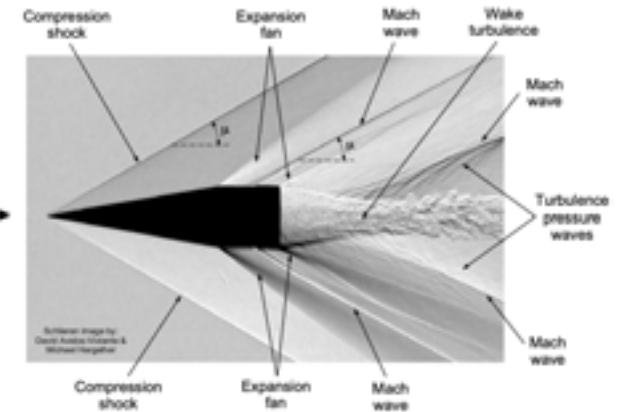
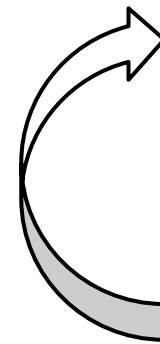
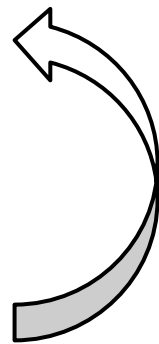
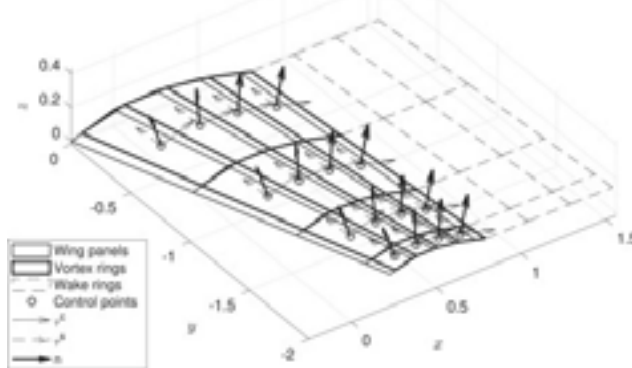
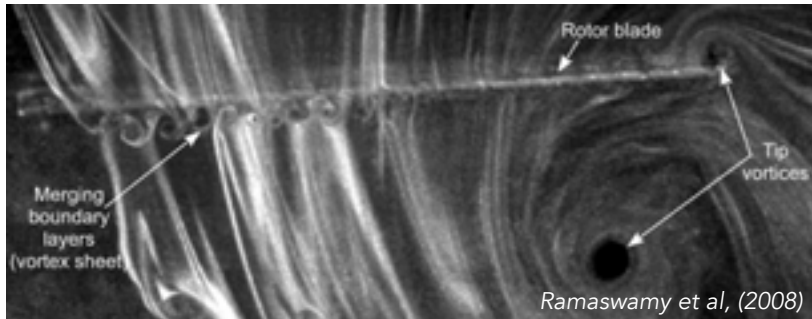

(MV, DSO, unpublished)

Can the deduced principles and surrogate models be shown to converge to established principles in tractable regimes?

- Renormalized vortex lattice methods and other modifications for unsteady flow
- Scaling approaches and functional variants of characteristic parameters
- Perturbative approaches to extend to/from inviscid-incompressible regimes

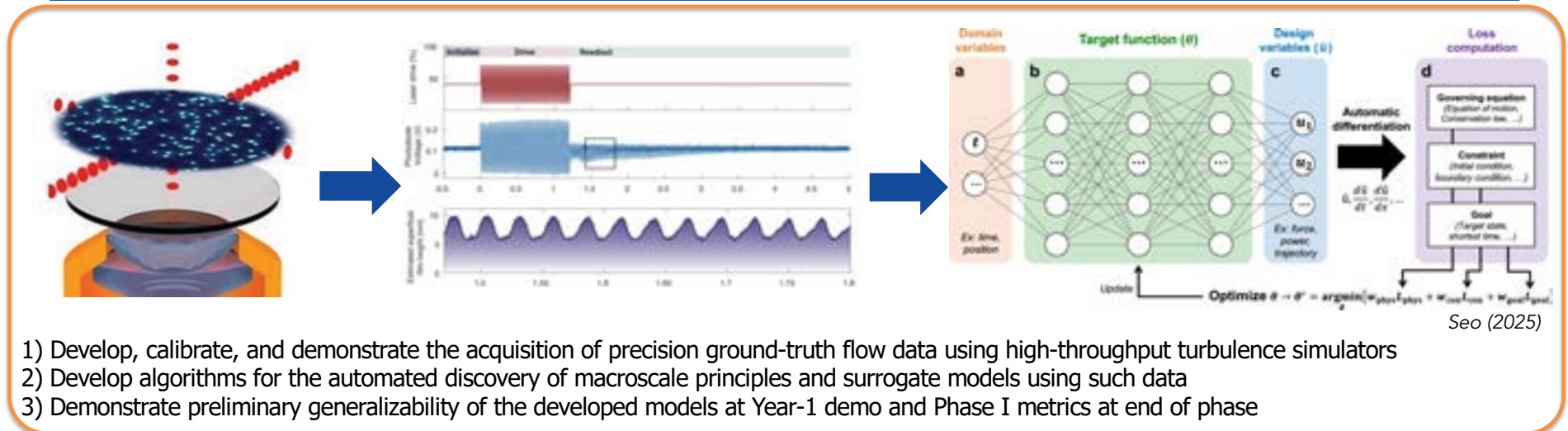

- 1) Develop, calibrate, and demonstrate the acquisition of precision ground-truth flow data using high-throughput turbulence simulators
- 2) Develop algorithms for the automated discovery of macroscale principles and surrogate models using such data
- 3) Demonstrate preliminary generalizability of the developed models at Year-1 demo and Phase I metrics at end of phase

Phase I Metric: Predictive models over 100x in design-relevant parameter range with >95% accuracy

Example applications:

- Multi-objective optimization across flight conditions from take-off to cruise
- OTA optical links from weak turbulence (<10 fs timing error) to strong turbulence (> ps timing error)
- SW/BL dynamics across operational regimes of Ram/Scramjet engines

Validation

- Validate emergent models from first principles (in tractable regimes)
- Validate against SOA direct numerical simulations and computational techniques
- Calibrated measurements in established wind tunnel facilities



Year-1 Demo and Down-select



A preliminary validation and performer down selection will occur at the **end of Year-1** of the period of performance. Proposers are required to include a performer-defined benchmark demonstration to validate their approach.

- **What will be tested?**
 - The surrogate models or macroscale design principles will be tested for universality in operationally relevant regimes. The performance prediction for a design could also serve as a preliminary validation.
- **How are test thresholds determined?**
 - The benchmarks for this demo can be performer-defined. For example, a performer could test their model's ability to predict the range covered by a golf ball, a performer-defined quantity, as a function of the swing, another performer-defined quantity. As another example, a performer could demonstrate universality in a macroscale principle across large parameter ranges.
- **How will the tests be validated?**
 - The year-1 validation process could involve confirmation with CFD computations, experimental data, extant data from literature or a combination thereof.



AutoDIDACTS Phase II: Challenge problems



Produce and demonstrate designs or protocols whose performance will be tested against challenge problem metrics. Topic areas include, but are not limited to:

Low Reynolds Number Regimes

Challenge problems could involve demonstration of MAVs with specified hover endurance, aerodynamic efficiency, aero-acoustic optimization, and related performance enhancements.



Supersonic and Hypersonic Flow Regimes

Challenge problems could involve development of predictive modeling for improved design of stable propulsion mechanisms, optimization of structures for improved aerodynamic performance, and design of active control techniques for improved aeronautical performance.



Transonic and Transitional Flow Regimes

Challenge problems could involve demonstration of passive, active, and/or adaptive techniques to mitigate transonic buffet, aeroelastic surrogate models with improved predictive capabilities in unstable regimes, and low-latency optimal control techniques for expanded flight envelopes.

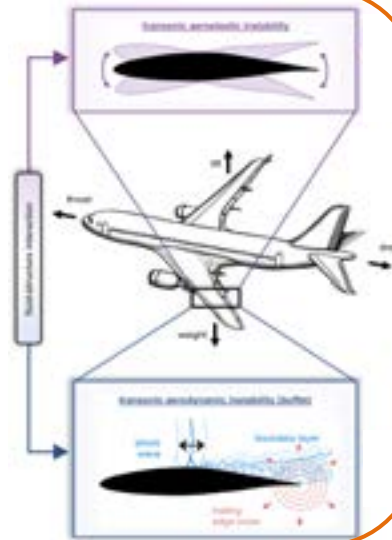

Optimal protocols for over-the-air optical communications and signal processing

Challenge problems could involve development of predictive modeling for improved predictive models of the effects of turbulence for low-light imaging, and development of optimal protocols for high-bandwidth communication and precision time transfer in the optical and microwave domains.

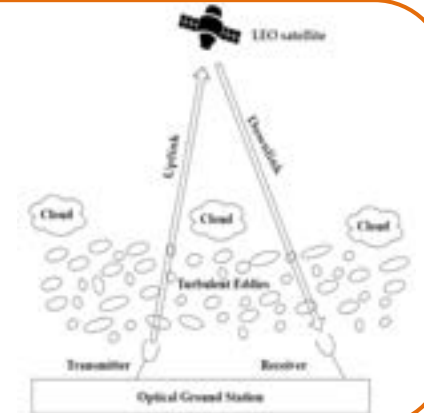

*** Proposers are encouraged to propose additional topic areas**



Summary Phase I and Phase II



Phase I (24 months)

Develop generalizable macroscale design principles or surrogate models.

Year-1 Demo and downselect based on validity of proposed approach

End of Phase I metrics	
Generalizability of models and/or design principles	>100x in parameter space ²
Model Accuracy ¹	>95%

1. Model accuracy will be determined by independent government teams via comparisons to direct numerical simulations (DNS), calibrated measurements in established wind-tunnel facilities, and a combination thereof.
2. This can be interpreted to include generalizability across variations of a single parameter (e.g. Reynolds number, turbulence structure function etc.) or a combination of parameters (e.g. Mach Number x Specific Impulse etc.)

Phase II (24 months)

A future solicitation with detailed descriptions and metrics on challenge problems will be released.

DARPA will invite select teams from Phase I to submit a Phase II proposal. The invitation will be based upon Phase I performance in relation to the metrics.



Program Timeline

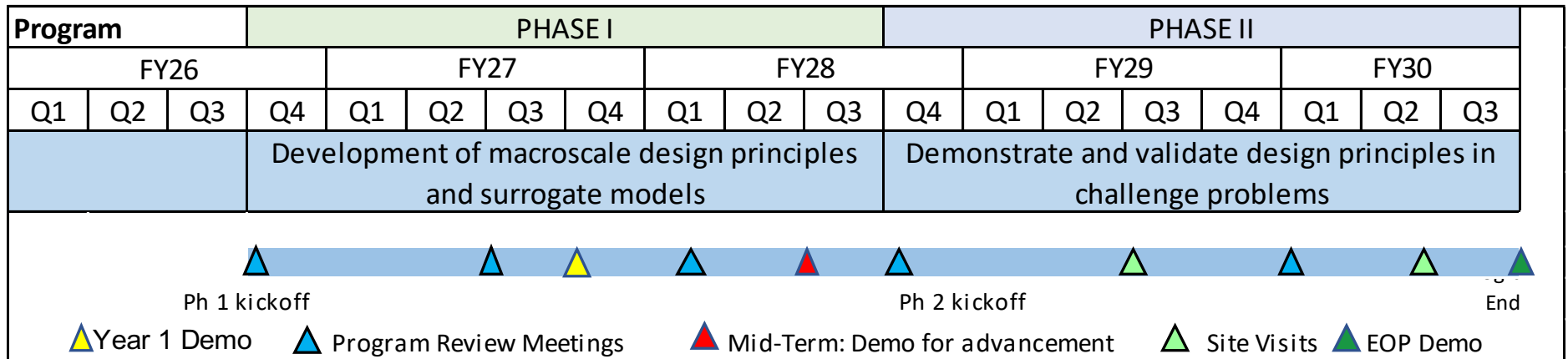



- The goals of the AutoDIDACTS Solicitation **cannot be met by isolated efforts** on quantum simulators, benchtop turbulence simulators, CFD or Machine learning. Close collaboration is essential.
- **Collaboration cannot be performative.** Proposals should present compelling evidence of how the collaboration is focused on the program goals and what each collaborator is bringing to the table.
- Development teams in the selected challenge problem topics may be included in Phase I teaming arrangements if such expertise will inform the data acquisition and modeling efforts. Proposals should clarify the roles of such teams during the proposed Phase I efforts.

Data-informed discovery of macroscale principles governing turbulent systems

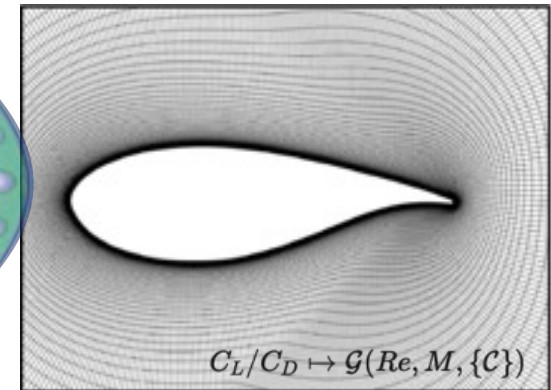
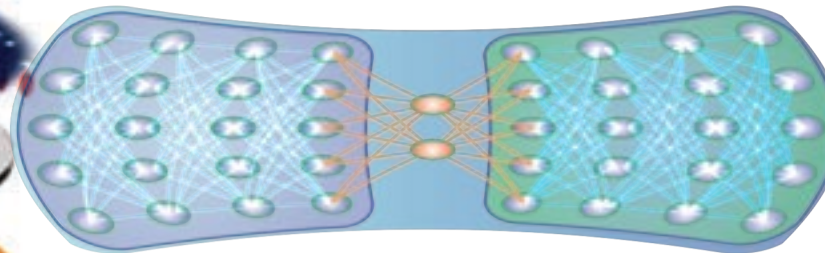
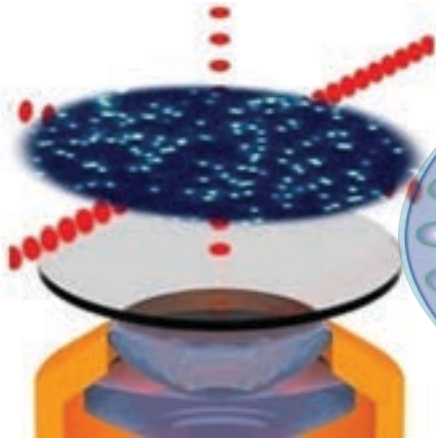



Requirements for Proposal



Proposals should include, at the minimum:

[More details in the BAA](#)

- 1) Description of the proposed approach, the required research and development efforts, and a description of what will be developed and demonstrated during the period of the program
- 2) Justification of how the proposed data-informed modeling enables generalizability, interpretability, and design optimization in the proposed regimes
- 3) Discussion on whether the proposed data-informed modeling is compatible with incremental and self-consistent inclusion of multi-physics models for multi-objective optimization and inverse design paradigms
- 4) An identification of risks associated with the proposed approach and corresponding risk mitigation strategies
- 5) Delineation of approaches and justifications for meeting the program goals and metrics
- 6) Proposers must identify an end-of-Year-1 demonstration as a preliminary validation of their proposed approach
- 7) Proposers must identify a topic area for the Phase II challenge problems that is most suited to their approach and justify how their proposed approach and teaming arrangements are suitable to addressing the identified topic area. Proposals must include a ROM cost for Phase II.

The following subjects are out of scope:

- X Computational/AI approaches to turbulence closure modeling
- X AI/ML modeling approaches based entirely on computational data
- X 'Black box' AI/ML modeling or optimization approaches
- X Modeling of non-universal design aspects or phenomenology
- X Material structures for hypersonic vehicles, surface chemistry and other non-turbulence related phenomenology



All Times are Eastern Time Zone (ET)



Tips for Successful Submission

- **Read the BAA carefully**
- Email questions to: AUTODIDACTS@darpa.mil
- FAQ: <https://www.darpa.mil/work-with-us/opportunities>
- Form complete teams with comprehensive expertise & capabilities
 - Teaming is necessary for this program





www.darpa.mil